

# D<sup>o</sup>

## HIGH TEMP

High-temperature  
dosing pump

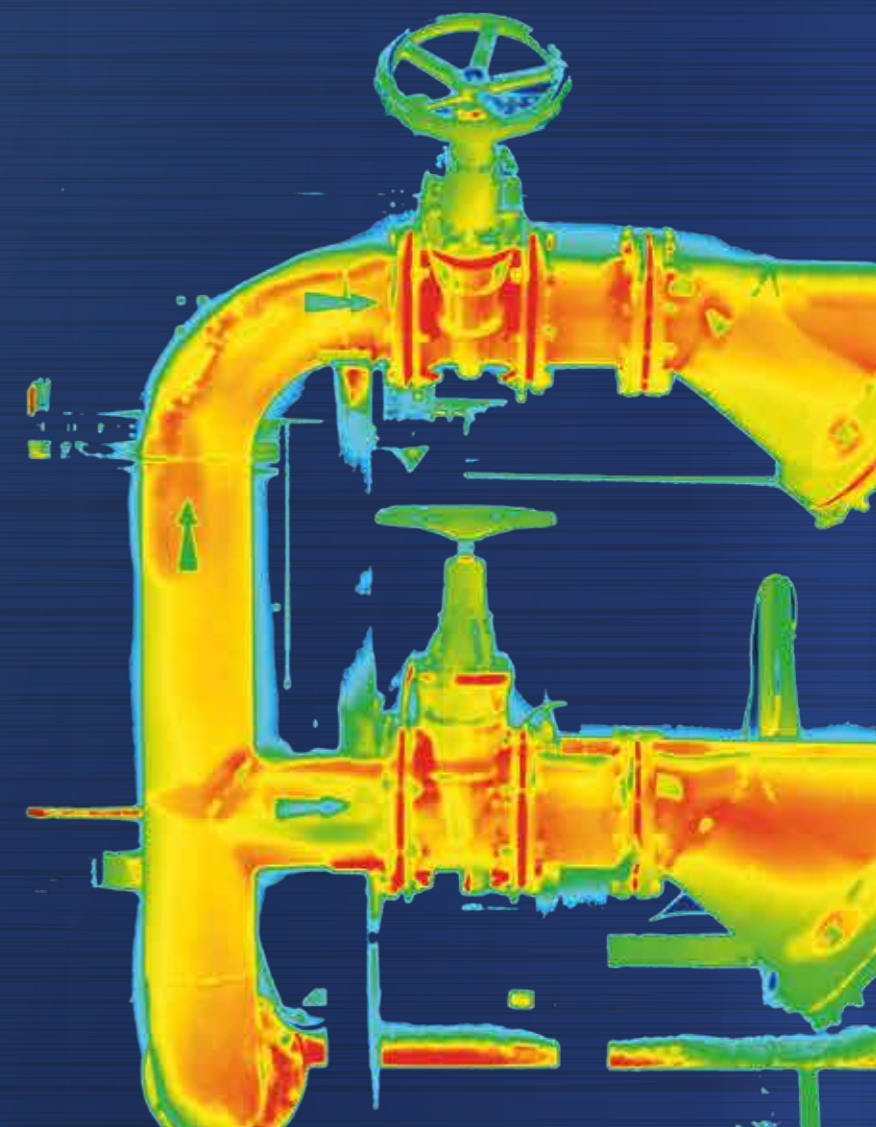

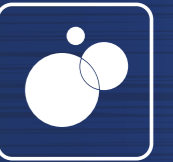

## High-temperature dosing pump



- Maximum effectiveness of the cleaning product thanks to high-temperature water dosing
- Compatible with all types of acid and alkaline chemicals used in clean-in-place and centralized cleaning systems
- Reliable and consistent dosing regardless of the number of satellites in operation
- Optimisation of water and chemical consumption
- Extremely easy to install, operate and maintain - plug & play

# D° HIGH TEMP

The **D° HIGH TEMP** high-temperature dosing pump features a set of innovative technologies which are the result of 5 years of research, field tests and mechanism improvements in order to guarantee its performance over the entire temperature range of the motive fluid, up to 70°C.



We have developed a special heat-sensitive label that indicates the temperature level of motive fluid, taking into account the thermal conductivity of the housing.



The spring-loaded lips mechanically compensate for any expansion caused by high temperatures.



Particular attention has been paid to the choice and quality of the materials, with the aim of limiting friction, maintaining pressure levels and increasing the mechanical strength of the dosing pump.

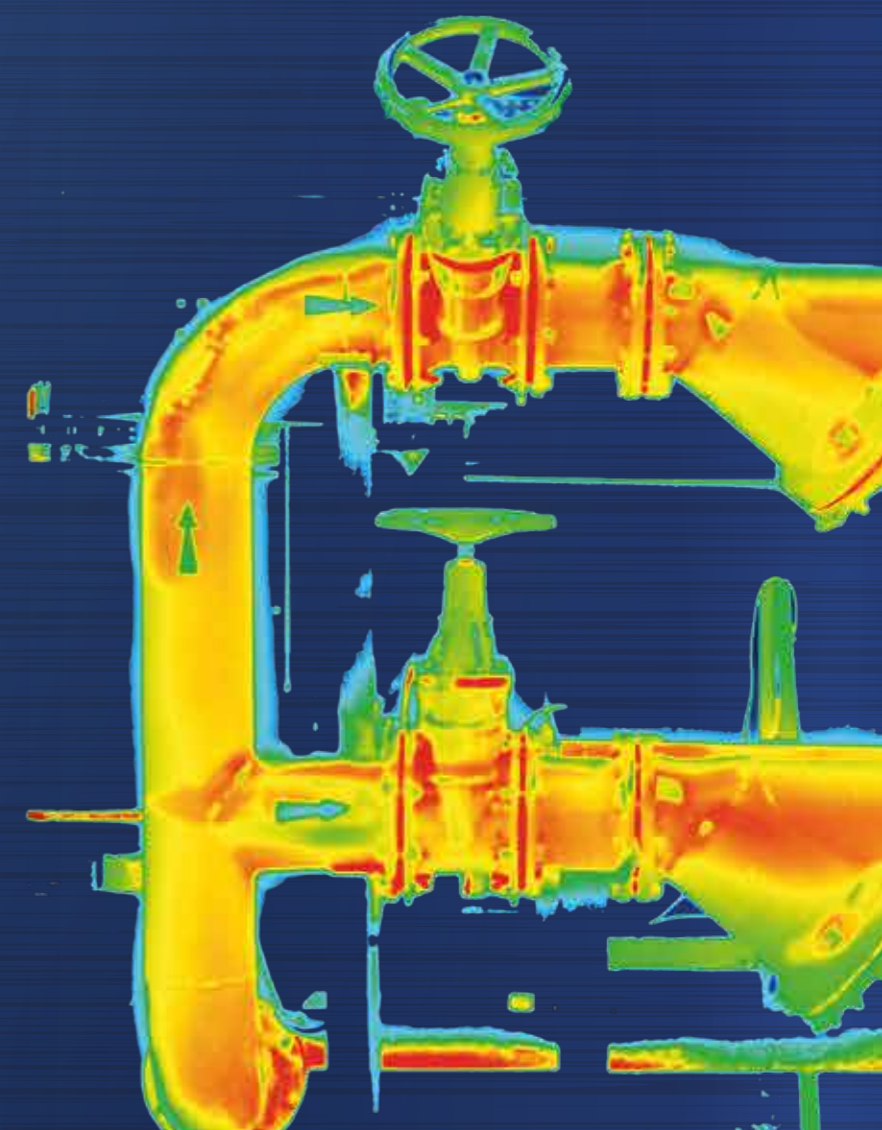



Satellites

Standard installation

Disinfection conveyor

Pump trolley

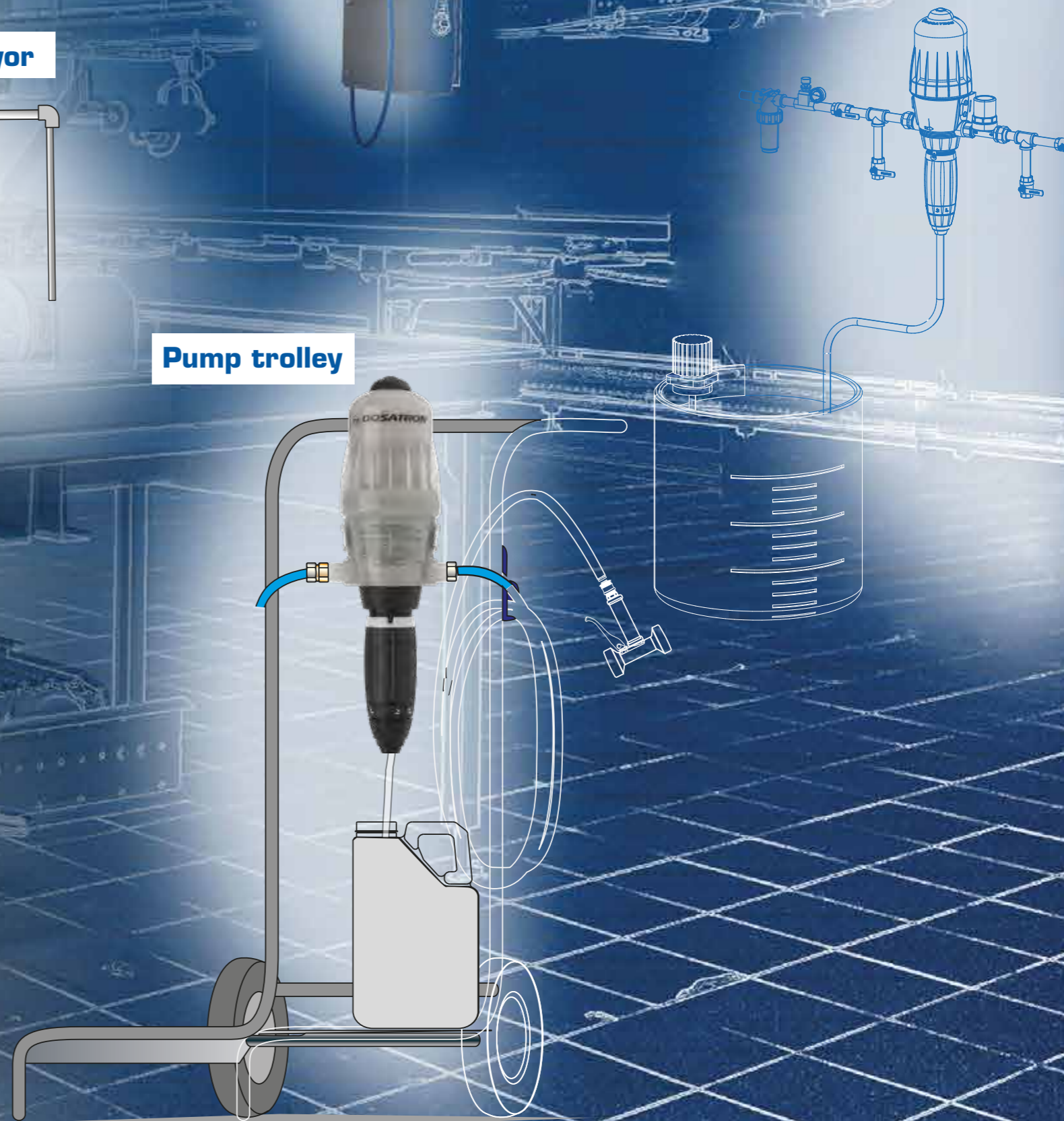



# Technical specifications

	D3TRE3000	D3TRE5	D3TRE10
Operating flow min./max.	100 l/h mini - 3 m <sup>3</sup> /h maxi [0.4 US Pint/min (min.) – 14 US GPM (max.)]		
Maximum operating temperature	<b>70 °C / 158 °F</b>		
Operating water pressure min./max.	0.3 – 6 bar [4.3 PSI – 85 PSI]		0.5 – 6 bar [7 PSI – 85 PSI]
Dosing % min./max.	0.03% to 0,3% 1:3000 - 1:333	0.5% to 5% 1:200 - 1:20	1% to 10% 1:100 - 1:10
Connection	3/4" M BSP/NPT - Ø20x27mm		

